

## PAGING

- Bits 51:12 are from the PTE.
- Bits 11:0 are from the original linear address.

If the P flag (bit 0) of a PDE or a PTE is 0 or if a PDE or a PTE sets any reserved bit, the entry is used neither to reference another paging-structure entry nor to map a page. A reference using a linear address whose translation would use such a paging-structure entry causes a page-fault exception (see Section 4.7).

The following bits are reserved with PAE paging:

- If the P flag (bit 0) of a PDE or a PTE is 1, bits 62:MAXPHYADDR are reserved.
- If the P flag and the PS flag (bit 7) of a PDE are both 1, bits 20:13 are reserved.
- If IA32\_EFER.NXE = 0 and the P flag of a PDE or a PTE is 1, the XD flag (bit 63) is reserved.
- If the PAT is not supported:<sup>1</sup>
  - If the P flag of a PTE is 1, bit 7 is reserved.
  - If the P flag and the PS flag of a PDE are both 1, bit 12 is reserved.

A reference using a linear address that is successfully translated to a physical address is performed only if allowed by the access rights of the translation; see Section 4.6.

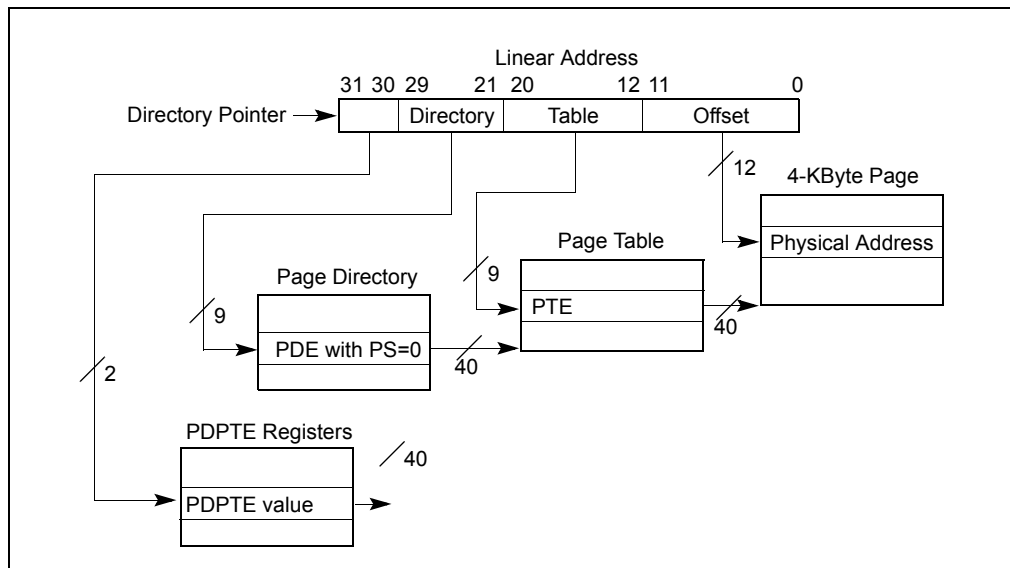

**Figure 4-5. Linear-Address Translation to a 4-KByte Page using PAE Paging**

1. See Section 4.1.4 for how to determine whether the PAT is supported.

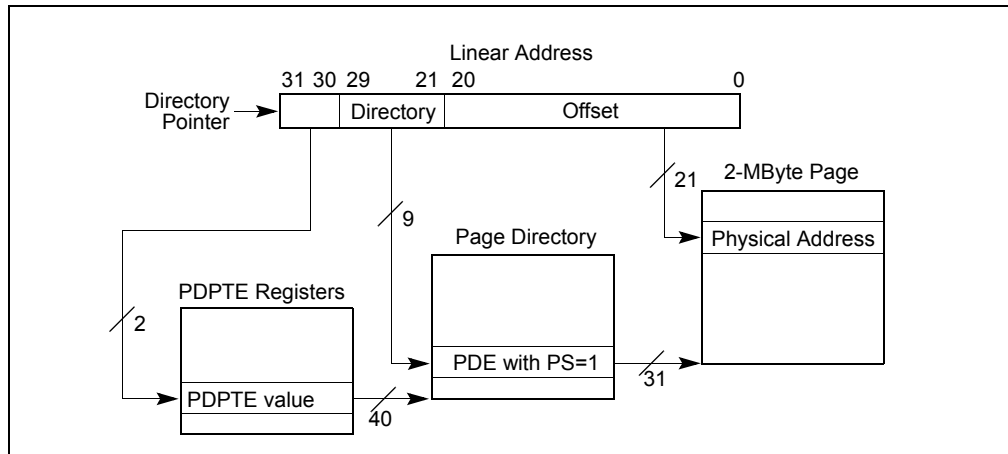

**Figure 4-6. Linear-Address Translation to a 2-MByte Page using PAE Paging**

**Table 4-9. Format of a PAE Page-Directory Entry that Maps a 2-MByte Page**

Bit Position(s)	Contents
0 (P)	Present; must be 1 to map a 2-MByte page
1 (R/W)	Read/write; if 0, writes may not be allowed to the 2-MByte page referenced by this entry (depends on CPL and CR0.WP; see Section 4.6)
2 (U/S)	User/supervisor; if 0, accesses with CPL=3 are not allowed to the 2-MByte page referenced by this entry (see Section 4.6)
3 (PWT)	Page-level write-through; indirectly determines the memory type used to access the 2-MByte page referenced by this entry (see Section 4.9)
4 (PCD)	Page-level cache disable; indirectly determines the memory type used to access the 2-MByte page referenced by this entry (see Section 4.9)
5 (A)	Accessed; indicates whether software has accessed the 2-MByte page referenced by this entry (see Section 4.8)
6 (D)	Dirty; indicates whether software has written to the 2-MByte page referenced by this entry (see Section 4.8)
7 (PS)	Page size; must be 1 (otherwise, this entry references a page table; see Table 4-10)