

# UNIX Implementation

*K. Thompson*

Bell Laboratories  
Murray Hill, New Jersey 07974

## ABSTRACT

This paper describes in high-level terms the implementation of the resident UNIX<sup>†</sup> kernel. This discussion is broken into three parts. The first part describes how the UNIX system views processes, users, and programs. The second part describes the I/O system. The last part describes the UNIX file system.

## 1. INTRODUCTION

The UNIX kernel consists of about 10,000 lines of C code and about 1,000 lines of assembly code. The assembly code can be further broken down into 200 lines included for the sake of efficiency (they could have been written in C) and 800 lines to perform hardware functions not possible in C.

This code represents 5 to 10 percent of what has been lumped into the broad expression “the UNIX operating system.” The kernel is the only UNIX code that cannot be substituted by a user to his own liking. For this reason, the kernel should make as few real decisions as possible. This does not mean to allow the user a million options to do the same thing. Rather, it means to allow only one way to do one thing, but have that way be the least-common divisor of all the options that might have been provided.

What is or is not implemented in the kernel represents both a great responsibility and a great power. It is a soap-box platform on “the way things should be done.” Even so, if “the way” is too radical, no one will follow it. Every important decision was weighed carefully. Throughout, simplicity has been substituted for efficiency. Complex algorithms are used only if their complexity can be localized.

## 2. PROCESS CONTROL

In the UNIX system, a user executes programs in an environment called a user process. When a system function is required, the user process calls the system as a subroutine. At some point in this call, there is a distinct switch of environments. After this, the process is said to be a system process. In the normal definition of processes, the user and system processes are different phases of the same process (they never execute simultaneously). For protection, each system process has its own stack.

The user process may execute from a read-only text segment, which is shared by all processes executing the same code. There is no *functional* benefit from shared-text segments. An *efficiency* benefit comes from the fact that there is no need to swap read-only segments out because the original copy on secondary memory is still current. This is a great benefit to interactive programs that tend to be swapped while waiting for terminal input. Furthermore, if two processes are executing simultaneously from the same copy of a read-only segment, only one copy needs to reside in primary memory. This is a secondary effect, because simultaneous execution of a program is not common. It is ironic that this effect, which reduces the use of primary memory, only comes into play when there is an overabundance of primary memory, that is, when there is enough memory to keep waiting processes loaded.

---

<sup>†</sup>UNIX is a Trademark of Bell Laboratories.

All current read-only text segments in the system are maintained from the *text table*. A text table entry holds the location of the text segment on secondary memory. If the segment is loaded, that table also holds the primary memory location and the count of the number of processes sharing this entry. When this count is reduced to zero, the entry is freed along with any primary and secondary memory holding the segment. When a process first executes a shared-text segment, a text table entry is allocated and the segment is loaded onto secondary memory. If a second process executes a text segment that is already allocated, the entry reference count is simply incremented.

A user process has some strictly private read-write data contained in its data segment. As far as possible, the system does not use the user's data segment to hold system data. In particular, there are no I/O buffers in the user address space.

The user data segment has two growing boundaries. One, increased automatically by the system as a result of memory faults, is used for a stack. The second boundary is only grown (or shrunk) by explicit requests. The contents of newly allocated primary memory is initialized to zero.

Also associated and swapped with a process is a small fixed-size system data segment. This segment contains all the data about the process that the system needs only when the process is active. Examples of the kind of data contained in the system data segment are: saved central processor registers, open file descriptors, accounting information, scratch data area, and the stack for the system phase of the process. The system data segment is not addressable from the user process and is therefore protected.

Last, there is a process table with one entry per process. This entry contains all the data needed by the system when the process is *not* active. Examples are the process's name, the location of the other segments, and scheduling information. The process table entry is allocated when the process is created, and freed when the process terminates. This process entry is always directly addressable by the kernel.

Figure 1 shows the relationships between the various process control data. In a sense, the process table is the definition of all processes, because all the data associated with a process may be accessed starting from the process table entry.

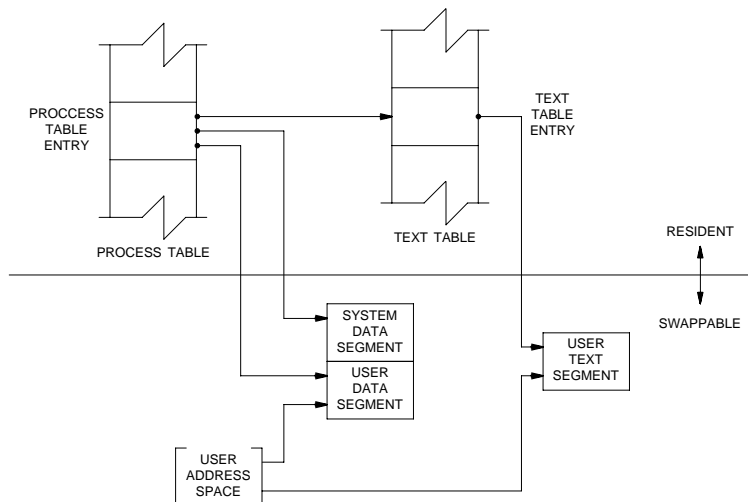

Fig. 1—Process control data structure.

## 2.1. Process creation and program execution

Processes are created by the system primitive **fork**. The newly created process (child) is a copy of the original process (parent). There is no detectable sharing of primary memory between the two processes. (Of course, if the parent process was executing from a read-only text segment, the child will share the text segment.) Copies of all writable data segments are made for the child process. Files that were open before the **fork** are truly shared after the **fork**. The processes are informed as to their part in the relationship to allow them to select their own (usually non-identical) destiny. The parent may **wait**

for the termination of any of its children.

A process may **exec** a file. This consists of exchanging the current text and data segments of the process for new text and data segments specified in the file. The old segments are lost. Doing an **exec** does *not* change processes; the process that did the **exec** persists, but after the **exec** it is executing a different program. Files that were open before the **exec** remain open after the **exec**.

If a program, say the first pass of a compiler, wishes to overlay itself with another program, say the second pass, then it simply **execs** the second program. This is analogous to a “goto.” If a program wishes to regain control after **execing** a second program, it should **fork** a child process, have the child **exec** the second program, and have the parent **wait** for the child. This is analogous to a “call.” Breaking up the call into a binding followed by a transfer is similar to the subroutine linkage in SL-5.<sup>1</sup>

## 2.2. Swapping

The major data associated with a process (the user data segment, the system data segment, and the text segment) are swapped to and from secondary memory, as needed. The user data segment and the system data segment are kept in contiguous primary memory to reduce swapping latency. (When low-latency devices, such as bubbles, CCDs, or scatter/gather devices, are used, this decision will have to be reconsidered.) Allocation of both primary and secondary memory is performed by the same simple first-fit algorithm. When a process grows, a new piece of primary memory is allocated. The contents of the old memory is copied to the new memory. The old memory is freed and the tables are updated. If there is not enough primary memory, secondary memory is allocated instead. The process is swapped out onto the secondary memory, ready to be swapped in with its new size.

One separate process in the kernel, the swapping process, simply swaps the other processes in and out of primary memory. It examines the process table looking for a process that is swapped out and is ready to run. It allocates primary memory for that process and reads its segments into primary memory, where that process competes for the central processor with other loaded processes. If no primary memory is available, the swapping process makes memory available by examining the process table for processes that can be swapped out. It selects a process to swap out, writes it to secondary memory, frees the primary memory, and then goes back to look for a process to swap in.

Thus there are two specific algorithms to the swapping process. Which of the possibly many processes that are swapped out is to be swapped in? This is decided by secondary storage residence time. The one with the longest time out is swapped in first. There is a slight penalty for larger processes. Which of the possibly many processes that are loaded is to be swapped out? Processes that are waiting for slow events (i.e., not currently running or waiting for disk I/O) are picked first, by age in primary memory, again with size penalties. The other processes are examined by the same age algorithm, but are not taken out unless they are at least of some age. This adds hysteresis to the swapping and prevents total thrashing.

These swapping algorithms are the most suspect in the system. With limited primary memory, these algorithms cause total swapping. This is not bad in itself, because the swapping does not impact the execution of the resident processes. However, if the swapping device must also be used for file storage, the swapping traffic severely impacts the file system traffic. It is exactly these small systems that tend to double usage of limited disk resources.

## 2.3. Synchronization and scheduling

Process synchronization is accomplished by having processes wait for events. Events are represented by arbitrary integers. By convention, events are chosen to be addresses of tables associated with those events. For example, a process that is waiting for any of its children to terminate will wait for an event that is the address of its own process table entry. When a process terminates, it signals the event represented by its parent's process table entry. Signaling an event on which no process is waiting has no effect. Similarly, signaling an event on which many processes are waiting will wake all of them up. This differs considerably from Dijkstra's P and V synchronization operations,<sup>2</sup> in that no memory is associated with events. Thus there need be no allocation of events prior to their use. Events exist simply by being used.

On the negative side, because there is no memory associated with events, no notion of “how much” can be signaled via the event mechanism. For example, processes that want memory might wait on an event associated with memory allocation. When any amount of memory becomes available, the event would be signaled. All the competing processes would then wake up to fight over the new memory. (In reality, the swapping process is the only process that waits for primary memory to become available.)

If an event occurs between the time a process decides to wait for that event and the time that process enters the wait state, then the process will wait on an event that has already happened (and may never happen again). This race condition happens because there is no memory associated with the event to indicate that the event has occurred; the only action of an event is to change a set of processes from wait state to run state. This problem is relieved largely by the fact that process switching can only occur in the kernel by explicit calls to the event-wait mechanism. If the event in question is signaled by another process, then there is no problem. But if the event is signaled by a hardware interrupt, then special care must be taken. These synchronization races pose the biggest problem when UNIX is adapted to multiple-processor configurations.<sup>3</sup>

The event-wait code in the kernel is like a co-routine linkage. At any time, all but one of the processes has called event-wait. The remaining process is the one currently executing. When it calls event-wait, a process whose event has been signaled is selected and that process returns from its call to event-wait.

Which of the runnable processes is to run next? Associated with each process is a priority. The priority of a system process is assigned by the code issuing the wait on an event. This is roughly equivalent to the response that one would expect on such an event. Disk events have high priority, teletype events are low, and time-of-day events are very low. (From observation, the difference in system process priorities has little or no performance impact.) All user-process priorities are lower than the lowest system priority. User-process priorities are assigned by an algorithm based on the recent ratio of the amount of compute time to real time consumed by the process. A process that has used a lot of compute time in the last real-time unit is assigned a low user priority. Because interactive processes are characterized by low ratios of compute to real time, interactive response is maintained without any special arrangements.

The scheduling algorithm simply picks the process with the highest priority, thus picking all system processes first and user processes second. The compute-to-real-time ratio is updated every second. Thus, all other things being equal, looping user processes will be scheduled round-robin with a 1-second quantum. A high-priority process waking up will preempt a running, low-priority process. The scheduling algorithm has a very desirable negative feedback character. If a process uses its high priority to hog the computer, its priority will drop. At the same time, if a low-priority process is ignored for a long time, its priority will rise.

### 3. I/O SYSTEM

The I/O system is broken into two completely separate systems: the block I/O system and the character I/O system. In retrospect, the names should have been “structured I/O” and “unstructured I/O,” respectively; while the term “block I/O” has some meaning, “character I/O” is a complete misnomer.

Devices are characterized by a major device number, a minor device number, and a class (block or character). For each class, there is an array of entry points into the device drivers. The major device number is used to index the array when calling the code for a particular device driver. The minor device number is passed to the device driver as an argument. The minor number has no significance other than that attributed to it by the driver. Usually, the driver uses the minor number to access one of several identical physical devices.

The use of the array of entry points (configuration table) as the only connection between the system code and the device drivers is very important. Early versions of the system had a much less formal connection with the drivers, so that it was extremely hard to handcraft differently configured systems. Now it is possible to create new device drivers in an average of a few hours. The configuration table in

most cases is created automatically by a program that reads the system's parts list.

### **3.1. Block I/O system**

The model block I/O device consists of randomly addressed, secondary memory blocks of 512 bytes each. The blocks are uniformly addressed 0, 1, ... up to the size of the device. The block device driver has the job of emulating this model on a physical device.

The block I/O devices are accessed through a layer of buffering software. The system maintains a list of buffers (typically between 10 and 70) each assigned a device name and a device address. This buffer pool constitutes a data cache for the block devices. On a read request, the cache is searched for the desired block. If the block is found, the data are made available to the requester without any physical I/O. If the block is not in the cache, the least recently used block in the cache is renamed, the correct device driver is called to fill up the renamed buffer, and then the data are made available. Write requests are handled in an analogous manner. The correct buffer is found and relabeled if necessary. The write is performed simply by marking the buffer as "dirty." The physical I/O is then deferred until the buffer is renamed.

The benefits in reduction of physical I/O of this scheme are substantial, especially considering the file system implementation. There are, however, some drawbacks. The asynchronous nature of the algorithm makes error reporting and meaningful user error handling almost impossible. The cavalier approach to I/O error handling in the UNIX system is partly due to the asynchronous nature of the block I/O system. A second problem is in the delayed writes. If the system stops unexpectedly, it is almost certain that there is a lot of logically complete, but physically incomplete, I/O in the buffers. There is a system primitive to flush all outstanding I/O activity from the buffers. Periodic use of this primitive helps, but does not solve, the problem. Finally, the associativity in the buffers can alter the physical I/O sequence from that of the logical I/O sequence. This means that there are times when data structures on disk are inconsistent, even though the software is careful to perform I/O in the correct order. On non-random devices, notably magnetic tape, the inversions of writes can be disastrous. The problem with magnetic tapes is "cured" by allowing only one outstanding write request per drive.

### **3.2. Character I/O system**

The character I/O system consists of all devices that do not fall into the block I/O model. This includes the "classical" character devices such as communications lines, paper tape, and line printers. It also includes magnetic tape and disks when they are not used in a stereotyped way, for example, 80-byte physical records on tape and track-at-a-time disk copies. In short, the character I/O interface means "everything other than block." I/O requests from the user are sent to the device driver essentially unaltered. The implementation of these requests is, of course, up to the device driver. There are guidelines and conventions to help the implementation of certain types of device drivers.

#### **3.2.1. Disk drivers**

Disk drivers are implemented with a queue of transaction records. Each record holds a read/write flag, a primary memory address, a secondary memory address, and a transfer byte count. Swapping is accomplished by passing such a record to the swapping device driver. The block I/O interface is implemented by passing such records with requests to fill and empty system buffers. The character I/O interface to the disk drivers create a transaction record that points directly into the user area. The routine that creates this record also insures that the user is not swapped during this I/O transaction. Thus by implementing the general disk driver, it is possible to use the disk as a block device, a character device, and a swap device. The only really disk-specific code in normal disk drivers is the pre-sort of transactions to minimize latency for a particular device, and the actual issuing of the I/O request.

#### **3.2.2. Character lists**

Real character-oriented devices may be implemented using the common code to handle character lists. A character list is a queue of characters. One routine puts a character on a queue. Another gets a character from a queue. It is also possible to ask how many characters are currently on a queue. Storage for all queues in the system comes from a single common pool. Putting a character on a queue

will allocate space from the common pool and link the character onto the data structure defining the queue. Getting a character from a queue returns the corresponding space to the pool.

A typical character-output device (paper tape punch, for example) is implemented by passing characters from the user onto a character queue until some maximum number of characters is on the queue. The I/O is prodded to start as soon as there is anything on the queue and, once started, it is sustained by hardware completion interrupts. Each time there is a completion interrupt, the driver gets the next character from the queue and sends it to the hardware. The number of characters on the queue is checked and, as the count falls through some intermediate level, an event (the queue address) is signaled. The process that is passing characters from the user to the queue can be waiting on the event, and refill the queue to its maximum when the event occurs.

A typical character input device (for example, a paper tape reader) is handled in a very similar manner.

Another class of character devices is the terminals. A terminal is represented by three character queues. There are two input queues (raw and canonical) and an output queue. Characters going to the output of a terminal are handled by common code exactly as described above. The main difference is that there is also code to interpret the output stream as ASCII characters and to perform some translations, e.g., escapes for deficient terminals. Another common aspect of terminals is code to insert real-time delay after certain control characters.

Input on terminals is a little different. Characters are collected from the terminal and placed on a raw input queue. Some device-dependent code conversion and escape interpretation is handled here. When a line is complete in the raw queue, an event is signaled. The code catching this signal then copies a line from the raw queue to a canonical queue performing the character erase and line kill editing. User read requests on terminals can be directed at either the raw or canonical queues.

### **3.2.3. Other character devices**

Finally, there are devices that fit no general category. These devices are set up as character I/O drivers. An example is a driver that reads and writes unmapped primary memory as an I/O device. Some devices are too fast to be treated a character at time, but do not fit the disk I/O mold. Examples are fast communications lines and fast line printers. These devices either have their own buffers or “borrow” block I/O buffers for a while and then give them back.

## **4. THE FILE SYSTEM**

In the UNIX system, a file is a (one-dimensional) array of bytes. No other structure of files is implied by the system. Files are attached anywhere (and possibly multiply) onto a hierarchy of directories. Directories are simply files that users cannot write. For a further discussion of the external view of files and directories, see Ref. 4.

The UNIX file system is a disk data structure accessed completely through the block I/O system. As stated before, the canonical view of a “disk” is a randomly addressable array of 512-byte blocks. A file system breaks the disk into four self-identifying regions. The first block (address 0) is unused by the file system. It is left aside for booting procedures. The second block (address 1) contains the so-called “super-block.” This block, among other things, contains the size of the disk and the boundaries of the other regions. Next comes the i-list, a list of file definitions. Each file definition is a 64-byte structure, called an i-node. The offset of a particular i-node within the i-list is called its i-number. The combination of device name (major and minor numbers) and i-number serves to uniquely name a particular file. After the i-list, and to the end of the disk, come free storage blocks that are available for the contents of files.

The free space on a disk is maintained by a linked list of available disk blocks. Every block in this chain contains a disk address of the next block in the chain. The remaining space contains the address of up to 50 disk blocks that are also free. Thus with one I/O operation, the system obtains 50 free blocks and a pointer where to find more. The disk allocation algorithms are very straightforward. Since all allocation is in fixed-size blocks and there is strict accounting of space, there is no need to compact or garbage collect. However, as disk space becomes dispersed, latency gradually increases.

Some installations choose to occasionally compact disk space to reduce latency.

An i-node contains 13 disk addresses. The first 10 of these addresses point directly at the first 10 blocks of a file. If a file is larger than 10 blocks (5,120 bytes), then the eleventh address points at a block that contains the addresses of the next 128 blocks of the file. If the file is still larger than this (70,656 bytes), then the twelfth block points at up to 128 blocks, each pointing to 128 blocks of the file. Files yet larger (8,459,264 bytes) use the thirteenth address for a “triple indirect” address. The algorithm ends here with the maximum file size of 1,082,201,087 bytes.

A logical directory hierarchy is added to this flat physical structure simply by adding a new type of file, the directory. A directory is accessed exactly as an ordinary file. It contains 16-byte entries consisting of a 14-byte name and an i-number. The root of the hierarchy is at a known i-number (*viz.*, 2). The file system structure allows an arbitrary, directed graph of directories with regular files linked in at arbitrary places in this graph. In fact, very early UNIX systems used such a structure. Administration of such a structure became so chaotic that later systems were restricted to a directory tree. Even now, with regular files linked multiply into arbitrary places in the tree, accounting for space has become a problem. It may become necessary to restrict the entire structure to a tree, and allow a new form of linking that is subservient to the tree structure.

The file system allows easy creation, easy removal, easy random accessing, and very easy space allocation. With most physical addresses confined to a small contiguous section of disk, it is also easy to dump, restore, and check the consistency of the file system. Large files suffer from indirect addressing, but the cache prevents most of the implied physical I/O without adding much execution. The space overhead properties of this scheme are quite good. For example, on one particular file system, there are 25,000 files containing 130M bytes of data-file content. The overhead (i-node, indirect blocks, and last block breakage) is about 11.5M bytes. The directory structure to support these files has about 1,500 directories containing 0.6M bytes of directory content and about 0.5M bytes of overhead in accessing the directories. Added up any way, this comes out to less than a 10 percent overhead for actual stored data. Most systems have this much overhead in padded trailing blanks alone.

#### 4.1. File system implementation

Because the i-node defines a file, the implementation of the file system centers around access to the i-node. The system maintains a table of all active i-nodes. As a new file is accessed, the system locates the corresponding i-node, allocates an i-node table entry, and reads the i-node into primary memory. As in the buffer cache, the table entry is considered to be the current version of the i-node. Modifications to the i-node are made to the table entry. When the last access to the i-node goes away, the table entry is copied back to the secondary store i-list and the table entry is freed.

All I/O operations on files are carried out with the aid of the corresponding i-node table entry. The accessing of a file is a straightforward implementation of the algorithms mentioned previously. The user is not aware of i-nodes and i-numbers. References to the file system are made in terms of path names of the directory tree. Converting a path name into an i-node table entry is also straightforward. Starting at some known i-node (the root or the current directory of some process), the next component of the path name is searched by reading the directory. This gives an i-number and an implied device (that of the directory). Thus the next i-node table entry can be accessed. If that was the last component of the path name, then this i-node is the result. If not, this i-node is the directory needed to look up the next component of the path name, and the algorithm is repeated.

The user process accesses the file system with certain primitives. The most common of these are **open**, **create**, **read**, **write**, **seek**, and **close**. The data structures maintained are shown in Fig. 2.

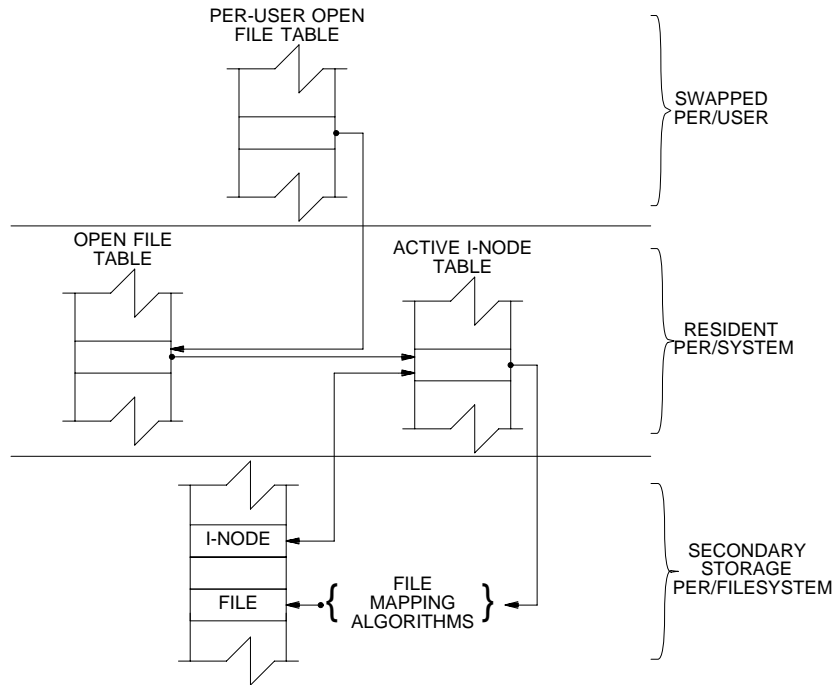

Fig. 2—File system data structure.

In the system data segment associated with a user, there is room for some (usually between 10 and 50) open files. This open file table consists of pointers that can be used to access corresponding i-node table entries. Associated with each of these open files is a current I/O pointer. This is a byte offset of the next read/write operation on the file. The system treats each read/write request as random with an implied seek to the I/O pointer. The user usually thinks of the file as sequential with the I/O pointer automatically counting the number of bytes that have been read/written from the file. The user may, of course, perform random I/O by setting the I/O pointer before reads/writes.

With file sharing, it is necessary to allow related processes to share a common I/O pointer and yet have separate I/O pointers for independent processes that access the same file. With these two conditions, the I/O pointer cannot reside in the i-node table nor can it reside in the list of open files for the process. A new table (the open file table) was invented for the sole purpose of holding the I/O pointer. Processes that share the same open file (the result of **forks**) share a common open file table entry. A separate open of the same file will only share the i-node table entry, but will have distinct open file table entries.

The main file system primitives are implemented as follows. **open** converts a file system path name into an i-node table entry. A pointer to the i-node table entry is placed in a newly created open file table entry. A pointer to the file table entry is placed in the system data segment for the process. **create** first creates a new i-node entry, writes the i-number into a directory, and then builds the same structure as for an **open**. **read** and **write** just access the i-node entry as described above. **seek** simply manipulates the I/O pointer. No physical seeking is done. **close** just frees the structures built by **open** and **create**. Reference counts are kept on the open file table entries and the i-node table entries to free these structures after the last reference goes away. **unlink** simply decrements the count of the number of directories pointing at the given i-node. When the last reference to an i-node table entry goes away, if the i-node has no directories pointing to it, then the file is removed and the i-node is freed. This delayed removal of files prevents problems arising from removing active files. A file may be removed while still open. The resulting unnamed file vanishes when the file is closed. This is a method of obtaining temporary files.

There is a type of unnamed FIFO file called a **pipe**. Implementation of **pipes** consists of implied **seeks** before each **read** or **write** in order to implement first-in-first-out. There are also checks and synchronization to prevent the writer from grossly outproducing the reader and to prevent the reader from overtaking the writer.



## 4.2. Mounted file systems

The file system of a UNIX system starts with some designated block device formatted as described above to contain a hierarchy. The root of this structure is the root of the UNIX file system. A second formatted block device may be mounted at any leaf of the current hierarchy. This logically extends the current hierarchy. The implementation of mounting is trivial. A mount table is maintained containing pairs of designated leaf i-nodes and block devices. When converting a path name into an i-node, a check is made to see if the new i-node is a designated leaf. If it is, the i-node of the root of the block device replaces it.

Allocation of space for a file is taken from the free pool on the device on which the file lives. Thus a file system consisting of many mounted devices does not have a common pool of free secondary storage space. This separation of space on different devices is necessary to allow easy unmounting of a device.

## 4.3. Other system functions

There are some other things that the system does for the user—a little accounting, a little tracing/debugging, and a little access protection. Most of these things are not very well developed because our use of the system in computing science research does not need them. There are some features that are missed in some applications, for example, better inter-process communication.

The UNIX kernel is an I/O multiplexer more than a complete operating system. This is as it should be. Because of this outlook, many features are found in most other operating systems that are missing from the UNIX kernel. For example, the UNIX kernel does not support file access methods, file disposition, file formats, file maximum size, spooling, command language, logical records, physical records, assignment of logical file names, logical file names, more than one character set, an operator's console, an operator, log-in, or log-out. Many of these things are symptoms rather than features. Many of these things are implemented in user software using the kernel as a tool. A good example of this is the command language.<sup>5</sup> Each user may have his own command language. Maintenance of such code is as easy as maintaining user code. The idea of implementing "system" code with general user primitives comes directly from MULTICS.<sup>6</sup>

## References

1. R. E. Griswold and D. R. Hanson, "An Overview of SL5," *SIGPLAN Notices* **12**(4), pp.40-50 (April 1977).
2. E. W. Dijkstra, "Cooperating Sequential Processes," pp. 43-112 in *Programming Languages*, ed. F. Genuys, Academic Press, New York (1968).
3. J. A. Hawley and W. B. Meyer, "MUNIX, A Multiprocessing Version of UNIX," M.S. Thesis, Naval Postgraduate School, Monterey, Cal.(1975).
4. D. M. Ritchie and K. Thompson, "The UNIX Time-Sharing System," *Bell Sys. Tech. J.* **57**(6), pp.1905-1929 (1978).
5. S. R. Bourne, "UNIX Time-Sharing System: The UNIX Shell," *Bell Sys. Tech. J.* **57**(6), pp.1971-1990 (1978).
6. E. I. Organick, *The MULTICS System*, M.I.T. Press, Cambridge, Mass. (1972).

